

SAN JAMAR IN-COUNTER PRODUCT SPECIFICATION INFORMATION

EZ-Fit® Cup Dispensers

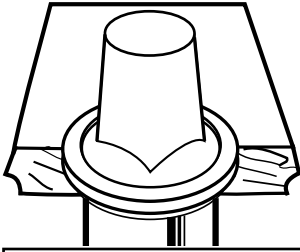

SUGGESTED SPECIFICATION:

Counter mount type cup dispenser. High impact plastic construction. Flexible gasket type dispensing utilizing a hexagon shaped gasket. Units to have cup holder, spring, and removable bottom, without use of tools for cleaning. Must be NSF listed. To be manufactured by San Jamar, Elkhorn, Wisconsin 53121 USA.

Construction: high-impact plastic

Item Number	Description	Cup Size	Rim Diameter	Tube Length	Case Pack	Case Cube	Case Weight	Counter Hole Diameter
C2210C	One-Size Fits-All Euro EZ-Fit®	6-24 oz (178-710 ml)	2 7/8"-3 11/16" (73-94 mm)	23 1/2" (597 mm)	1	0.54	3 lbs (1.4 kgs)	4 7/8" 124mm
C2210C18	One-Size Fits-All Euro EZ-Fit®	6-24 oz (178-710 ml)	2 7/8"-3 11/16" (73-94 mm)	18" (457 mm)	1	0.54	2.3 lbs (1.04 kgs)	4 7/8" 124mm
C2410C	One-Size-Fits-All EZ-Fit®	8-46 oz (236-1360 ml)	2 7/8"-4 3/4" (73-121 mm)	23 1/2" (597 mm)	1	0.74	4 lbs (1.81 kgs)	5 1/4" 145mm
C2410C18	One-Size-Fits-All EZ-Fit®	8-46 oz (236-1360 ml)	2 7/8"-4 3/4" (73-121 mm)	18" (457 mm)	1	0.74	3 lbs (1.4 kgs)	5 1/4" 145mm
C2510C	Large Deli Cup EZ-Fit®	32-64 oz (950-1890 ml)	4 3/16"-5 1/4" (106-133 mm)	22 1/2" (572 mm)	1	1.0	4 lbs (1.81 kgs)	6 3/8" 168mm

Item Number	Description	Cup Size	Rim Diameter	Tube Length	Case Pack	Case Cube	Case Weight	Counter Hole Diameter
C2010C	Portion Cup EZ-Fit®	1/2-2 1/2 oz (15-70 ml)	1 1/2"-2 5/16" (38-59 mm)	16" (406 mm)	1	0.23	1.5 lbs (0.68 kgs)	3 1/4" 83mm

Stainless Steel Adjustable Cup Dispensers

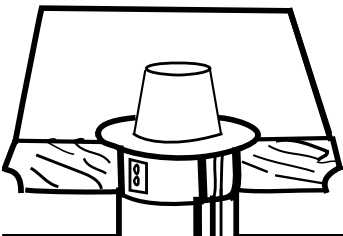

SUGGESTED SPECIFICATION:

Counter Mount-Type cup dispenser. Brushed steel tube: collar style adjustment: self supporting mounting bracket: removable from counter without the use of tools. Units to have anti-jam cup holder, spring and removable bottom, without use of tools for cleaning. To be manufactured by San Jamar, Elkhorn, Wisconsin 53121, USA

Construction: 26-gauge 304 stainless; 18" (457 mm) tube available upon request

Item Number	Description	Cup Size	Rim Diameter	Tube Length	Case Pack	Case Cube	Case Weight	Counter Hole Diameter
C3200CF	for foam cups	6-10 oz	2 1/32"-3 3/16"	23 1/2"	1	0.55	3 lbs	4 3/8" 106mm
C3200CV	vertical mount	(180-300 ml)	(58-80 mm)	(597 mm)			(1.4 kgs)	4 3/8" 106mm
C3200CH	horizontal mount							4 3/8" 106mm
C3400CF	for foam cups	12-24 oz	2 3/4"-3 7/8"	23 1/2"	1	0.55	3.3 lbs	4 1/2" 119mm
C3400CV	vertical mount	(350-710 ml)	(70-98 mm)	(597 mm)			(1.5 kgs)	4 1/2" 119mm
C3400CH	horizontal mount							4 1/2" 119mm
C3500CF	for foam cups	32-46 oz	4"-4 7/8"	23 1/2"	1	0.74	4.8 lbs	5 1/4" 145mm
C3500CV	vertical mount	(950-1360 ml)	(101-123 mm)	(597 mm)			(2.2 kgs)	5 1/4" 145mm
C3500CH	horizontal mount							5 1/4" 145mm

Item Number	Description	Diameter	Case Pack	Case Cube	Case Weight	Counter Hole Diameter
CA32KT	Adapter ring kit (convert to C3200)	6 3/4" (171 mm)	1	0.03	0.8 lbs (0.36 kgs)	5 1/4" 145mm
CA34KT	Adapter ring kit (convert to C3400)	6 3/4" (171 mm)	1	0.03	0.8 lbs (0.36 kgs)	5 1/4" 145mm

FrontLine™ Soft-Touch™ Pump

SUGGESTED SPECIFICATION:

Pump to be constructed of high impact plastic in BLACK/METAL FINISH with contoured lever style handle. Pump body is to be fully disassembled without use of tools for cleaning and NSF listed for clean-in-place. Maximum stroke yields 1 ounce with gauging collars supplied to reduce yield in 1/4 oz. increments. To be manufactured by San Jamar, Elkhorn, Wisconsin 53121 USA.

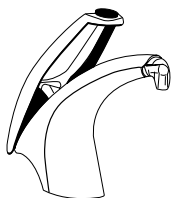

Item Number	Description	Case Pack	Case Cube	Case Weight
P4000	Soft-Touch™ Pump metal finish	1	0.17	1.4 lbs (0.64 kgs)
P4000BK	Soft-Touch™ Pump black	1	0.17	1.4 lbs (0.64 kgs)

Mounting Dimensions

COUNTER HOLE DIMENSIONS

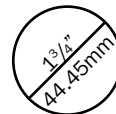

Mounting Plate Thickness:

1/32" (0.79 mm) minimum; 3/32" (2.36 mm) maximum

Minimum clearance diameter for tightening locknut:

3 1/4" (82.55 mm)

NOTE: call for complete specifications on mounting the Soft-Touch™ Pump in custom applications.

FrontLine™ Universal In-Counter Dispensing Systems

SUGGESTED SPECIFICATION:

Unit to contain Soft-Touch pump (listed above), stainless steel lid and black molded plastic vessel. Unit cover to contain tamper-resistant spring latch without threads. To include connector for 1.5 gallon Cryovac® condiment pouch. To be manufactured by San Jamar, Elkhorn, Wisconsin 53121 USA.

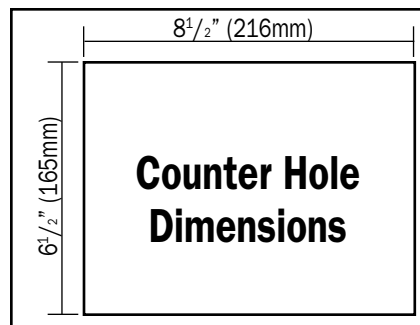
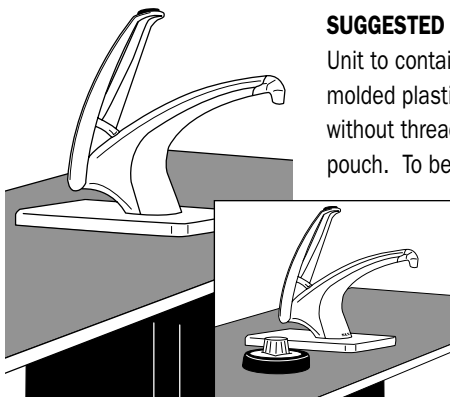

Item Number	Center Includes	Dimensions	Case Pack	Case Cube	Case Weight
P4100	(1 ea) universal condiment dispenser with metal finish pump, tamper resistant lid, liner, Cryovac® bag adapter and plug, dip tube	12"h x 7 1/2"w x 9 1/2"d - container without pump (305h x 191w x 241d mm) 9 3/4"h x 7 1/2"w x 9 1/2"d - above counter with pump (248h x 191w x 241d mm)	1	0.77	4.5 lbs (2.04 kgs)
P4100BK	(1 ea) universal condiment dispenser with black pump, tamper resistant lid, liner, Cryovac® bag adapter and plug, dip tube	12"h x 7 1/2"w x 9 1/2"d - container without pump (305h x 191w x 241d mm) 9 3/4"h x 7 1/2"w x 9 1/2"d - above counter with pump (248h x 191w x 241d mm)	1	0.77	4.5 lbs (2.04 kgs)
P4120	(1 ea) P4100 universal in-counter condiment dispenser & C2010C EZ-Fit® portion cup dispenser	P4100 universal in-counter system: (see dimensions above) C2010C portion cup dispenser: (see dimensions on front page)	1	1.55	7.4 lbs (3.36 kgs)
P4120BK	(1 ea) P4100BK universal in-counter condiment dispenser & C2010C EZ-Fit® portion cup dispenser	P4100BK universal in-counter system: (see dimensions above) C2010C portion cup dispenser: (see dimensions on front page)	1	1.55	7.4 lbs (3.36 kgs)

FrontLine™ 7 Quart Round Cover and Pump Systems

SUGGESTED SPECIFICATION:

Unit to contain Soft-Touch pump (listed above) and stainless steel lid. Lid is designed to fit on standard 7 qt. round inset pan. Cover to contain tamper-resistant spring latch without threads. To be manufactured by San Jamar, Elkhorn, Wisconsin 53121 USA.

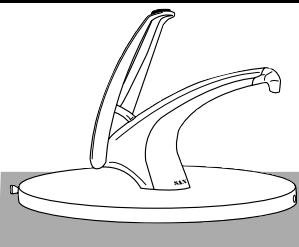

Counter Hole Dimensions

NOTE: container not included

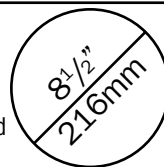

Item Number	Center Includes	Dimensions	Case Pack	Case Cube	Case Weight
P4710	metal finish pump and cover for 7 qt round inset; works best on containers with 9.45"(240mm) rim dia.	8 1/8"h x 9 1/2" diameter (including inset container) (206h x 241diameter mm)	1	0.24	2.6 lbs (1.18 kgs)
P4710BK	black pump and cover for 7 qt round inset; works best on containers with 9.45"(240mm) rim dia.	8 1/8"h x 9 1/2" diameter (including inset container) (206h x 241diameter mm)	1	0.24	2.6 lbs (1.18 kgs)

Napkin Dispensers

SUGGESTED SPECIFICATION:

Unit to have hidden self locking latch release on a hinged, pyramid shaped dispensing face. Construction shall be of a 22-gauge stainless steel box and an 18-gauge steel face with a finish of SC-SATIN CHROME/XC-CHROME/SS-STANLESS STEEL OR Construction shall be of a 22-gauge stainless steel box and an 18-gauge stainless steel framed, break-resistant plastic face with a color of TBK-TRANSPARENT BLACK PEARL/CL-CLEAR. Holes shall be provided to secure unit for mounting. To be manufactured by San Jamar, Elkhorn, Wisconsin 53121, USA

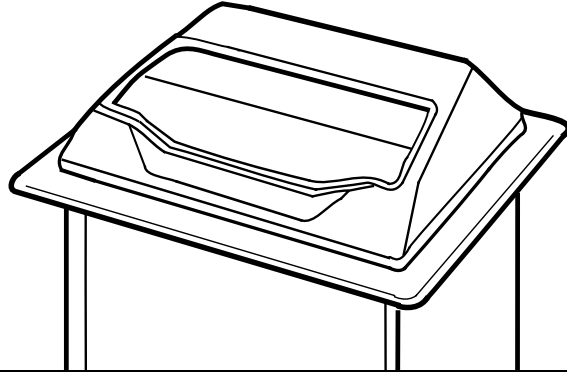
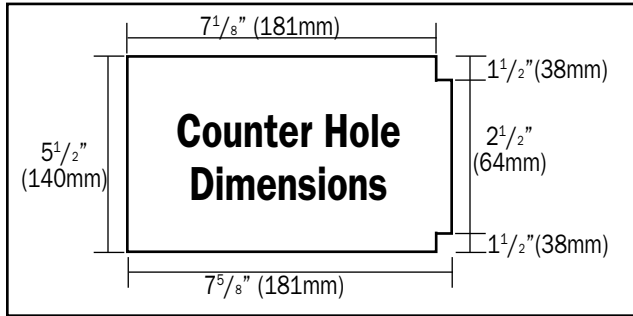

Item Number	Face Description	Capacity	Napkin Type	Dimensions	Case Pack	Case Cube	Case Weight
H2000XC	chrome	500+	minifold	19 5/8" h x 7" w x 5 1/2" d	1	0.88	8 lbs
H2000SS	stainless steel			(498h x 178w x 140d mm)			(3.6 kgs)
H2000SC	satin chrome						
H2000TBKSS	transparent black pearl						
H2001XC	chrome	500+	fullfold	19 5/8" h x 7" w x 5 1/2" d	1	0.88	8 lbs
H2001SS	stainless steel			(498h x 178w x 140d mm)			(3.6 kgs)
H2001SC	satin chrome						
H2001TBKSS	transparent black pearl						
H2001CLSS	clear						
H2002SC	satin chrome	500+	sidefold	19 5/8" h x 7" w x 5 1/2" d	1	0.88	8 lbs
				(498h x 178w x 140d mm)			(3.6 kgs)
H2003CLSS	clear	500+	interfold	19 5/8" h x 7" w x 5 1/2" d	1	0.88	8 lbs
				(498h x 178w x 140d mm)			(3.6 kgs)

Note: Clear face adaptable for future upgrades. 12" (305 mm) and 8" (203 mm) box lengths also available.

In-Counter Chilled Condiment Tray

SUGGESTED SPECIFICATION:

Counter mount type condiment organizer. Unit to have stainless steel frame and black molded plastic liner. Liner to contain two 1/6 size pans, which are covered by a clear hinged lid. Lid to be self-closing. To be manufactured by San Jamar, Elkhorn, WI 53121, USA.

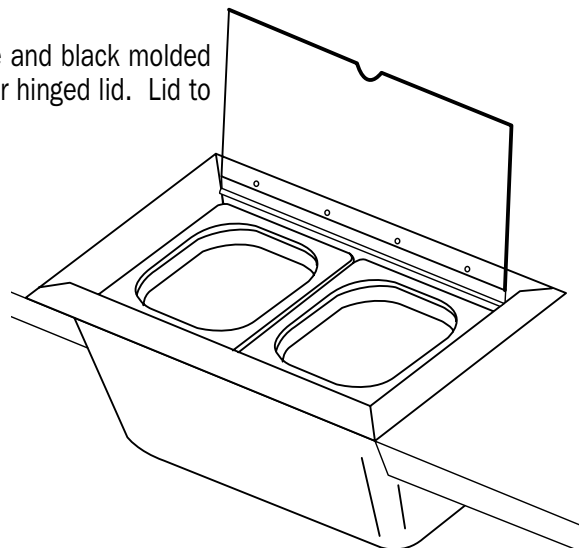
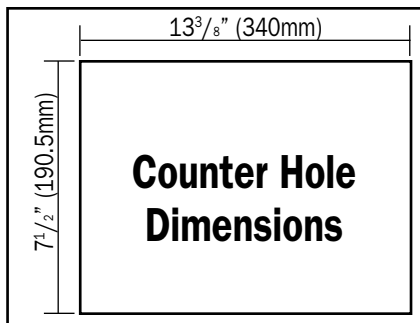

Item Number	Center Includes	Outside Trim Dimensions	Case Pack	Case Cube	Case Weight
FP3132	(1 ea) stainless steel frame, hinged lid, liner; (2) 1/6 size pans	16 1/8" w x 10 1/4" d (410w x 260d mm)	1	0.97	4.1 lbs (1.9 kgs)

Trash Chute/Straw Dispenser

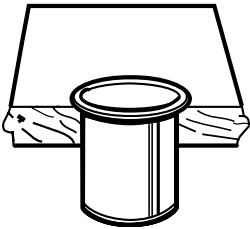

SUGGESTED SPECIFICATION:

Counter mount type trash chute/straw dispenser. Stainless steel construction. Self supporting mounting bracket. Removable from counter without use of tools. Units to have removable bottom, without use of tools for cleaning. To be manufactured by San Jamar, Elkhorn, Wisconsin 53121 USA.

Construction: 22-gauge 304 stainless

Item Number	Description	Rim Diameter	Tube Length	Case Pack	Case Cube	Case Weight	Counter Hole Diameter
L320C	trash chute or convert for use as a straw dispenser	5 ³ / ₈ " (136mm)	6" (152 mm)	1	0.19	1.1 lbs (0.5 kgs)	

Check Racks

SUGGESTED SPECIFICATION:

Slide Check Racks. Anodized aluminum construction. Glass marbles to withstand hot environments. Screw hole located in end caps to prevent loss of end caps. Screw hole position to allow mounting without blocking pass-through ability. To include stainless steel screw kit. To be manufactured by San Jamar, Elkhorn, Wisconsin 53121 USA.

Construction: Anodized Aluminum

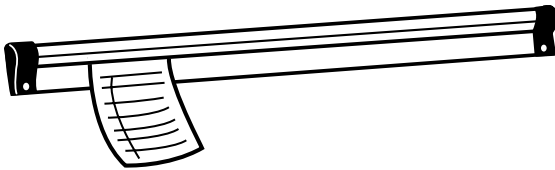

Item Number	Description (Length)	Dimensions	Case Pack	Case Cube	Case Weight
CK6512A	12" (305mm) slide check rack	All check racks have a height of 2"(51mm) and a depth of 3/4" (19mm)	6	0.08	2.8 lbs (1.3 kgs)
CK6518A	18" (457mm) slide check rack		6	0.16	4.2 lbs (1.9 kgs)
CK6524A	24" (610mm) slide check rack		6	0.16	5.5 lbs (2.5 kgs)
CK6530A	30" (762mm) slide check rack		6	0.19	6.9 lbs (3.1 kgs)
CK6536A	36" (915mm) slide check rack		6	0.23	8.3 lbs (3.8 kgs)
CK6544A	44" (1117mm) slide check rack		6	0.27	9.7 lbs (4.4 kgs)
CK6548A	48" (1220mm) slide check rack		6	0.30	11.0 lbs (5.0 kgs)
CK6560A	60" (1524mm) slide check rack		6	0.41	14.0 lbs (6.4 kgs)

Washroom Roll Towel Dispensers

For a complete line of San Jamar washroom dispensers, please see our catalog.

SUGGESTED SPECIFICATION:

Wall mount universal towel dispenser. Break-resistant plastic construction. Common key opens all units. Internal mechanisms are interchangeable without the use of tools. Jam resistant. Lever handle treated with Bio-Pruf® to inhibit bacteria growth. To be manufactured by San Jamar, Elkhorn, WI 53121 USA.

Construction: break-resistant plastic

Color Key: TBK - transparent black pearl
TBL - transparent arctic blue
WS - white sand

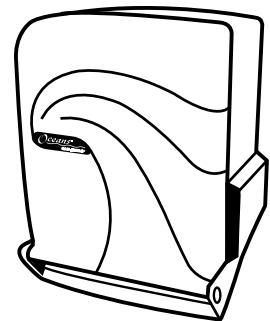

Item Number	Description	Capacity	Dimensions	Case Pack	Case Cube	Case Weight
T1490TBK	Smart System™ Touchless	(1) 8" (200mm) wide roll	15 ¹ / ₂ "h x 13"w x 9"d (394h x 330w x 229d mm)	1	1.67	7.1 lbs (3.2 kgs)
T1490TBL	Roll Towel Dispenser	8 ¹ / ₂ " (215mm) diameter;				
T1490WS	w/Infinity® System	and (1) 4" (100mm) stub roll				
T1390TBK	Tear-N-Dry™ Touchless	(1) 8" (200mm) wide roll	15 ¹ / ₂ "h x 13"w x 9"d (394h x 330w x 229d mm)	1	1.67	7.1 lbs (3.2 kgs)
T1390TBL	Roll Towel Dispenser	8 ¹ / ₂ " (215mm) diameter;				
T1390WS						
T1290TBK	Sawy® Lever	(1) 8" (200mm) wide roll	15 ¹ / ₂ "h x 13"w x 9"d (394h x 330w x 229d mm)	1	1.67	7.1 lbs (3.2 kgs)
T1290TBL	Roll Towel Dispenser	8 ¹ / ₂ " (215mm) diameter;				
T1290WS	w/Infinity® System	and (1) 4" (100mm) stub roll				

SAN JAMAR

Smart ♦ Safe ♦ Sanitary

555 Koopman Lane • Elkhorn, Wisconsin 53121 USA
T: 800.248.9826/262.723.6133 • F: 262.723.4204
www.sanjamar.com • Email: sanjamar@sanjamar.com