



Project \_\_\_\_\_  
 Item # \_\_\_\_\_  
 Quantity \_\_\_\_\_

## Cold Simulated Stone<sup>▲</sup> Shelves Built-In

Models: CSSB-2418, -3018, -3618, -4818  
 CSSBF-24-F, -24-I, -24-S, -36-F, -36-I, -36-S,  
 -48-F, -48-I, -48-S

Hatco's new Cold Simulated Stone<sup>▲</sup> Shelves are a must for buffet lines in cafeterias, restaurants and much more! These sturdy, foodsafe shelves are available in three attractive decorative stone colors.

### Standard features

- R-513A refrigerant available for California only, please contact Hatco for more information
- Patented thermal break reduces condensation and temperature transfer
- Long, flexible refrigerant line (ability to pull out condensing unit) for service
- The CSSB Cold Simulated Stone<sup>▲</sup> Shelves Built-In match the GRSSB Heated Simulated Stone<sup>▲</sup> Built-In Shelves for a fully integrated look
- Both CSSB and CSSBF models are bottom mount units, flush to countertop
- Models shipped with Electronic Temperature Control and condensing unit
- Control box can be mounted on the front of the cabinet, 4' (1219 mm) from center of shelf
- Condensing unit may be mounted up to 4' (1219 mm) away from the center of shelf
- Shelf construction utilizes R-404A refrigerant
- Easy serviceability with a sight glass, service valves, dryer/filter, and a receiver
- Models with simulated stone are Swanstone<sup>®</sup>

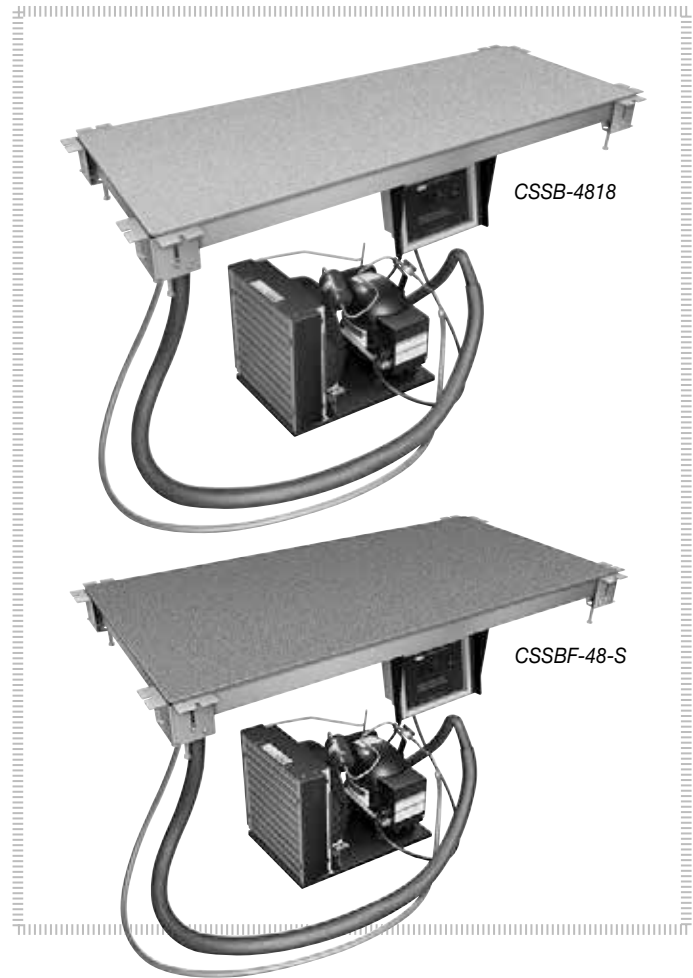

### Options (available at time of purchase only)

- Simulated Stone<sup>▲</sup> base color – Non-standard colors are non-returnable  
 Gray Granite  Bermuda Sand  Night Sky (standard)  
 Additional four year parts only warranty on the compressor available at time of purchase (U.S. and Canada only)

▲ Models with simulated stone are Swanstone<sup>®</sup>

**For operation, location and safety information, please refer to the Installation & Operating Manual.**

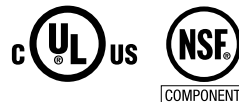

**HATCO CORPORATION** | P.O. Box 340500 Milwaukee, WI 53234-0500 U.S.A.  
 (800) 558-0607 | (414) 671-6350 | www.hatcocorp.com | support@hatcocorp.com



# Cold Simulated Stone<sup>^</sup> Shelves Built-In

Models: CSSB-2418, -3018, -3618, -4818

CSSBF-24-F, -24-I, -24-S, -36-F, -36-I, -36-S, -48-F, -48-I, -48-S

**CSSB, CSSBF**

**FRONT**

**SIDE**

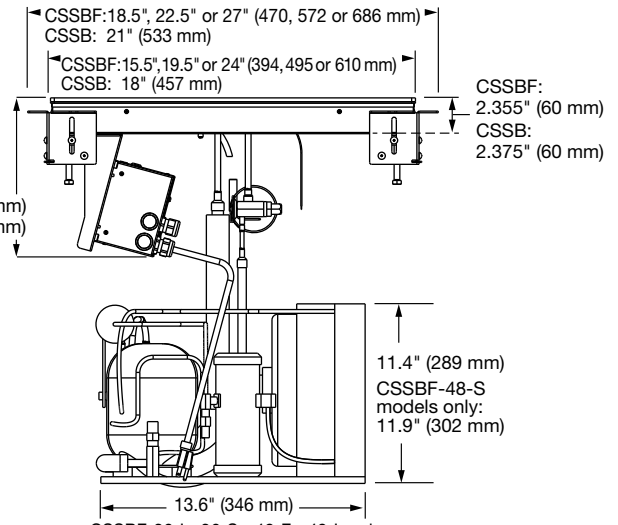
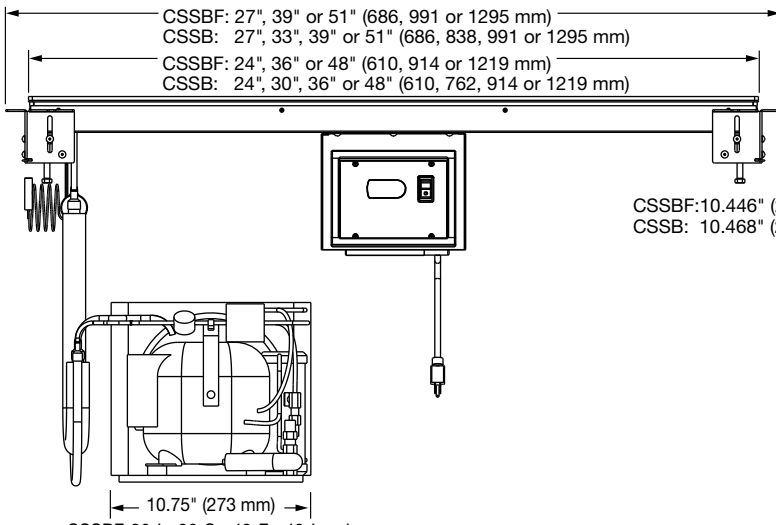

CSSBF-36-I, -36-S, -48-F, -48-I and  
 CSSB-4818 50 Hz models only: 12.1" (307 mm)  
 CSSBF-48-S models only: 12.1" (307 mm)

CSSBF-36-I, -36-S, -48-F, -48-I and  
 CSSB-4818 50 Hz models only: 16" (406 mm)  
 CSSBF-48-S models only: 17.4" (442 mm)

Contact Hatco for R-513A refrigerant specifications.

## SPECIFICATIONS

Cold Simulated Stone Shelves Built-In (flush to countertop)\* - All Single Phase

The shaded areas contain electrical information for International models

Model	Overall Dimension W x D x H	Usable Shelf Space W x D of cooled surface	Compressor Size HP	Volts*	Watts	Amps	Hz	Plug	Approximate Ship Weight
CSSB-2418	27" x 21" x 10.468" (686 x 533 x 266 mm)	24" x 18" (610 x 457 mm)	1/4	120	804	6.7	60	NEMA 5-15P	120 lb. (54 kg)
			1/3	220	616	2.8	50	CEE 7-7 Schuko, BS-1363, AS3112	
				230	667	2.9			
				240	744	3.1			
			1/3	220	686	3.1	60	CEE 7-7 Schuko, BS-1363	
				230	749	3.3			
240	816	3.4							
CSSB-3018	33" x 21" x 10.468" (838 x 533 x 266 mm)	30" x 18" (762 x 457 mm)	1/4	120	804	6.7	60	NEMA 5-15P	132 lb. (60 kg)
			1/3	220	616	2.8	50	CEE 7-7 Schuko, BS-1363, AS3112	
				230	667	2.9			
				240	744	3.1			
			1/3	220	686	3.1	60	CEE 7-7 Schuko, BS-1363	
				230	749	3.3			
240	816	3.4							
CSSB-3618	39" x 21" x 10.468" (991 x 533 x 266 mm)	36" x 18" (914 x 457 mm)	1/4	120	804	6.7	60	NEMA 5-15P	149 lb. (68 kg)
			1/3	220	616	2.8	50	CEE 7-7 Schuko, BS-1363, AS3112	
				230	667	2.9			
				240	744	3.1			
			1/3	220	686	3.1	60	CEE 7-7 Schuko, BS-1363	
				230	749	3.3			
240	816	3.4							
CSSB-4818	51" x 21" x 10.468" (1295 x 533 x 266 mm)	48" x 18" (1219 x 457 mm)	1/3	120	468	6.5	60	NEMA 5-15P	145 lb. (66 kg)
			3/8	220	807	3.7	50	CEE 7-7 Schuko, BS-1363, AS3112	
				230	882	3.8			
				240	960	4.0			
			1/3	220	686	3.1	60	CEE 7-7 Schuko, BS-1363	
				230	749	3.3			
240	816	3.4							

<sup>^</sup> Models with simulated stone are Swanstone<sup>®</sup>.

\* All voltages are non-CE.

\* Contact Hatco for R-513A refrigerant specifications.



# Cold Simulated Stone<sup>▲</sup> Shelves Built-In

Models: CSSB-2418, -3018, -3618, -4818

CSSBF-24-F, -24-I, -24-S, -36-F, -36-I, -36-S, -48-F, -48-I, -48-S

## SPECIFICATIONS

### Cold Simulated Stone Built-In Shelves - Flush Top\*

The shaded areas contain electrical information for International models

Model	Overall Dimension W x D x H	Usable Shelf Space W x D of cooled surface	Compressor Size HP	Volts*	Watts	Amps	Hz	Plug	Approximate Ship Weight
CSSBF-24-F	27" x 18.5" x 10.446" (686 x 470 x 265 mm)	24" x 15.5" (610 x 394 mm)	1/4	120	804	6.7	60	NEMA 5-15P	114 lb. (52 kg)
			1/3	220	616	2.8	50	CEE 7-7 Schuko, BS-1363, AS3112	
				230	667	2.9			
				240	744	3.1			
			1/3	220	686	3.1	60	CEE 7-7 Schuko BS-1363	
				230	749	3.3			
				240	816	3.4			
CSSBF-24-I	27" x 22.5" x 10.446" (686 x 572 x 265 mm)	24" x 19.5" (610 x 495 mm)	1/4	120	804	6.7	60	NEMA 5-15P	124 lb. (56 kg)
			1/3	220	616	2.8	50	CEE 7-7 Schuko, BS-1363, AS3112	
				230	667	2.9			
				240	744	3.1			
			1/3	220	686	3.1	60	CEE 7-7 Schuko BS-1363	
				230	749	3.3			
				240	816	3.4			
CSSBF-24-S	27" x 27" x 10.446" (686 x 686 x 265 mm)	24" x 24" (610 x 610 mm)	1/4	120	804	6.7	60	NEMA 5-15P	134 lb. (61 kg)
			1/3	220	616	2.8	50	CEE 7-7 Schuko, BS-1363, AS3112	
				230	667	2.9			
				240	744	3.1			
			1/3	220	686	3.1	60	CEE 7-7 Schuko BS-1363	
				230	749	3.3			
				240	816	3.4			
CSSBF-36-F	39" x 18.5" x 10.446" (991 x 470 x 265 mm)	36" x 15.5" (914 x 394 mm)	1/4	120	804	6.7	60	NEMA 5-15P	143 lb. (65 kg)
			1/3	220	616	2.8	50	CEE 7-7 Schuko, BS-1363, AS3112	
				230	667	2.9			
				240	744	3.1			
			1/3	220	686	3.1	60	CEE 7-7 Schuko BS-1363	
				230	749	3.3			
				240	816	3.4			
CSSBF-36-I	39" x 22.5" x 10.446" (991 x 572 x 265 mm)	36" x 19.5" (914 x 495 mm)	1/3	120	468	6.5	60	NEMA 5-15P	155 lb. (70 kg)
			3/8	220	807	3.7	50	CEE 7-7 Schuko, BS-1363, AS3112	
				230	882	3.8			
				240	960	4.0			
			1/3	220	686	3.1	60	CEE 7-7 Schuko, BS-1363	
				230	749	3.3			
				240	816	3.4			
CSSBF-36-S	39" x 27" x 10.446" (991 x 686 x 265 mm)	36" x 24" (914 x 610 mm)	1/3	120	468	6.5	60	NEMA 5-15P	167 lb. (78 kg)
			3/8	220	807	3.7	50	CEE 7-7 Schuko, BS-1363, AS3112	
				230	882	3.8			
				240	960	4.0			
			1/3	220	686	3.1	60	CEE 7-7 Schuko, BS-1363	
				230	749	3.3			
				240	816	3.4			
CSSBF-48-F	51" x 18.5" x 10.446" (1295 x 470 x 265 mm)	48" x 15.5" (1219 x 394 mm)	1/3	120	468	6.5	60	NEMA 5-15P	144 lb. (65 kg)
			3/8	220	807	3.7	50	CEE 7-7 Schuko, BS-1363, AS3112	
				230	882	3.8			
				240	960	4.0			
			1/3	220	686	3.1	60	CEE 7-7 Schuko, BS-1363	
				230	749	3.3			
				240	816	3.4			
CSSBF-48-I	51" x 22.5" x 10.446" (1295 x 572 x 265 mm)	48" x 19.5" (1219 x 495 mm)	1/3	120	468	6.5	60	NEMA 5-15P	173 lb. (78 kg)
			3/8	220	807	3.7	50	CEE 7-7 Schuko, BS-1363, AS3112	
				230	882	3.8			
				240	960	4.0			
			1/3	220	686	3.1	60	CEE 7-7 Schuko, BS-1363	
				230	749	3.3			
				240	816	3.4			
CSSBF-48-S	51" x 27" x 10.446" (1295 x 686 x 265 mm)	48" x 24" (1219 x 610 mm)	1/2	120	1380	11.5	60	NEMA 5-15P	195 lb. (89 kg)
			1/2	220	1190	5.4	50	CEE 7-7 Schuko, BS-1363, AS3112	
				230	1300	5.7			
				240	1416	5.9			
			1/2	220	1210	5.5	60	CEE 7-7 Schuko, BS-1363	
				230	1322	5.8			
				240	1440	6.0			

▲ Models with simulated stone are Swanstone®.

\* All voltages are non-CE.

\* Contact Hatco for R-513A refrigerant specifications.

**HATCO CORPORATION** | P.O. Box 340500 Milwaukee, WI 53234-0500 U.S.A.  
(800) 558-0607 | (414) 671-6350 | www.hatcocorp.com | support@hatcocorp.com



# Cold Simulated Stone<sup>^</sup> Shelves Built-In

Models: CSSB-2418, -3018, -3618, -4818

CSSBF-24-F, -24-I, -24-S, -36-F, -36-I, -36-S, -48-F, -48-I, -48-S

## PLUG CONFIGURATION

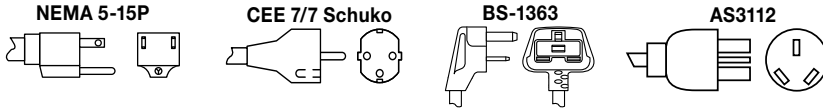

## COUNTERTOP CUTOUT DIMENSIONS

See Installation and Operating Manual for more information

Model	Width with .375" (10 mm) radii	Depth with .375" (10 mm) radii
CSSBF-24-F	24.375" (619 mm)	15.875" (403 mm)
CSSBF-24-I	24.375" (619 mm)	19.875" (505 mm)
CSSBF-24-S	24.375" (619 mm)	24.375" (619 mm)
CSSBF-36-F	36.375" (924 mm)	15.875" (403 mm)
CSSBF-36-I	36.375" (924 mm)	19.875" (505 mm)
CSSBF-36-S	36.375" (924 mm)	24.375" (619 mm)
CSSBF-48-F	48.375" (1229 mm)	15.875" (403 mm)
CSSBF-48-I	48.375" (1229 mm)	19.875" (505 mm)
CSSBF-48-S	48.375" (1229 mm)	24.375" (619 mm)
Model	Width with .375" (10 mm) radii	Depth with .375" (10 mm) radii
CSSB-2418	24.375" (619 mm)	18.375" (467 mm)
CSSB-3018	30.375" (772 mm)	18.375" (467 mm)
CSSB-3618	36.375" (924 mm)	18.375" (467 mm)
CSSB-4818	48.375" (1229 mm)	18.375" (467 mm)
Model	Width (should not exceed)	Height (should not exceed)
Control Box	7.44" (189 mm)	5.625" (143 mm)

## PRODUCT SPECS Cold Simulated Stone<sup>^</sup> Built-In Shelves

The Cold Simulated Stone Built-In Shelf, patent pending, shall be model ... as manufactured by the Hatco Corporation, Milwaukee, WI 53234 U.S.A.  
The Cold Simulated Stone Built-In Shelf shall be rated at ... watts, ... volts, and ... inches (millimeters) in overall width.

It shall utilize R-404A or R-513A refrigerant and consist of food-safe material, a condenser attached to evaporator with 5 foot (1524 mm) flexible tubing, and an adjustable bracket with cord and plug attached.

Warranty consists of 24/7 parts and service assistance (U.S. and Canada only).

<sup>^</sup> Models with simulated stone are Swanstone<sup>®</sup>

**HATCO CORPORATION** | P.O. Box 340500 Milwaukee, WI 53234-0500 U.S.A.  
(800) 558-0607 | (414) 671-6350 | www.hatcocorp.com | support@hatcocorp.com