



Project _____
 Item # _____
 Quantity _____

Glo-Ray® Fry Holding Station

Models: GRFHS-16, -21, -22, -26, -PTT21, -PT16, -PT26

Hatco offers convenient Glo-Ray® Fry Holding Stations that can be placed where they are most needed - next to a fryer! Glo-Ray heat technology offers you the ability to keep fried foods at optimum temperatures, ready to serve, without cooking or drying them out.

Standard features

- Ceramic heating elements above, allowing ample space between the warmer and food bin to empty baskets
- Pre-set thermostatically-controlled heated base maintains uniform holding temperatures from below
- Various hardcoated fry ribbons stage boxed or bagged products for quick service areas
- PT and PTT models are pass-through style
- Pass-thru tunnel is available with model GRFHS-PTT21
- Sectional divider permits holding of multiple products
- Models have 16.75", 18", or 20" (425, 457, or 508 mm) clearances
- Bottom trivet lifts food off the bottom of the station promoting air movement and reduces the build up of moisture



Options (available at time of purchase only)

- Halogen Bulb in lieu of Standard Display Light (60 watt)
- Left or Right side Cutout (GRFHS-16, -21, and -26) (Adds 1.7"(43 mm) to width of unit)
- 6" (15 mm) deep pan (GRFHS-PT26)

Accessories

- 4 Pleat Hardcoated Fry Box Ribbon (GRFHS-16 & -26)
- 5 Pleat Hardcoated Fry Bag Ribbon (GRFHS-16 & -26)
- 5 Pleat Hardcoated Fry Box Ribbon (GRFHS-21)
- 6 Pleat Hardcoated Fry Box/Bag Combo Ribbon (GRFHS-21)
- 7 Pleat Hardcoated Fry Bag Ribbon (GRFHS-21)
- 8 Pleat Hardcoated French Fry Bag Ribbon
- 8 Pleat Hardcoated Fry Box Ribbon (GRFHS-PT26 & PTT21)
- 9 Pleat Hardcoated Fry Box/Bag Combo Ribbon (GRFHS-PT26 & PTT21)
- 10 Pleat Hardcoated Fry Bag Ribbon (GRFHS-PT26 & PTT21)
- Additional Sectional Dividers (one standard per unit)
- 5" (127 mm) side-by-side bag holder (GRFHS-21)
- 5" (127 mm) piggy back bag holder (GRFHS-21 & -PTT21)
- Scoop Holder - adds 1.25" (32 mm) to overall product width for each scoop holder (one standard on GRFHS-PT26, -PTT21) (not available for the GRFHS-22)
- Food Pans (not available for the GRFHS-22)
- Wire Trivet (not available for the GRFHS-22)



HATCO CORPORATION | P.O. Box 340500 Milwaukee, WI 53234-0500 U.S.A.

(800) 558-0607 | (414) 671-6350 | www.hatcocorp.com | equipmentsales@hatcocorp.com | intl@hatcocorp.com



Glo-Ray® Fry Holding Station

Models: GRFHS-16, -21, -22, -26, -PTT21, -PT16, -PT26

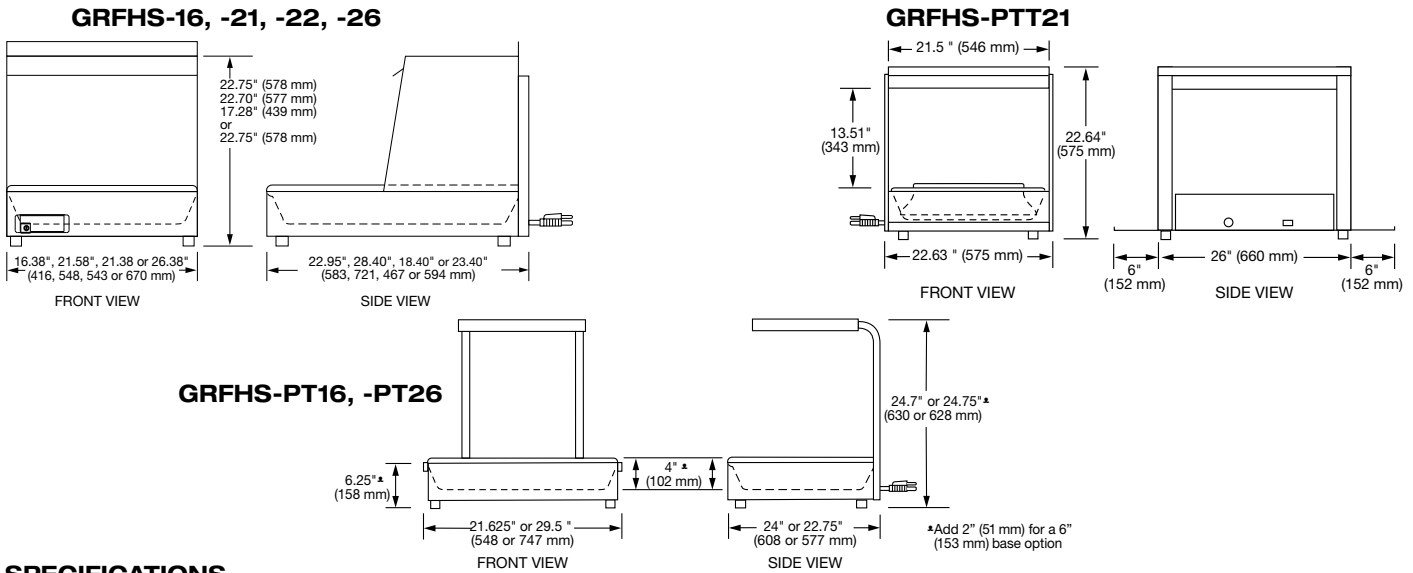

SPECIFICATIONS

Glo-Ray Fry Holding Station

The shaded areas contain electrical information for International models only

Model	Dimensions (Width x Depth x Height)	Volts	Phase	Watts	Amps	Plug	Ship Weight*
GRFHS-16	16.38" x 22.95" x 22.75" (416 x 583 x 578 mm)	100	Single	878	8.8	JIS C 8303	63 lbs. (29 kg)
		120		1090	9.1	NEMA 5-15P	
		220-230 (CE)		1057-1155	4.8-5.0	CEE 7/7 Schuko	
		230-240 (CE)		1019-1110	4.4-4.6	BS-1363 or AS 3112•	
GRFHS-PT16	21.58" x 23.95" x 24.875" (548 x 608 x 632 mm)	100	Single	861	8.6	JIS C 8303	60 lbs. (27 kg)
		120		1090	9.1	NEMA 5-15P	
GRFHS-21	21.58" x 28.40" x 22.70" (548 x 721 x 577 mm)	100	Single	1007	10.1	JIS C 8303	63 lbs. (29 kg)
		120		1200	10.0	NEMA 5-15P	
		220-230 (CE)		1218-1332	5.5-5.8	CEE 7/7 Schuko	
		230-240 (CE)		1102-1200	4.8-5.0	BS-1363 or AS 3112•	
GRFHS-PTT21	22.63" x 38" x 22.64" (575 x 965 x 575 mm)	100	Single	1347	13.5	JIS C 8303	100 lbs. (45 kg)
		120		1740	14.5	NEMA 5-15P†	
		220-230 (CE)		1486-1624	6.8-7.1	CEE 7/7 Schuko	
		230-240 (CE)		1624-1768	7.1-7.4	BS-1363 or AS 3112•	
GRFHS-22	21.38" x 18.40" x 17.28" (543 x 467 x 439 mm)	100	Single	847	8.5	JIS C 8303	44 lbs. (20 kg)
		120		1030	8.6	NEMA 5-15P	
GRFHS-26	26.38" x 23.40" x 22.75" (670 x 594 x 578 mm)	100	Single	1007	10.1	JIS C 8303	66 lbs. (30 kg)
		120		1200	10.0	NEMA 5-15P	
		220-230 (CE)		1243-1359	5.7-5.9	CEE 7/7 Schuko	
		230-240 (CE)		1128-1229	4.9-5.1	BS-1363 or AS 3112•	
GRFHS-PT26	29.4" x 22.71" x 24.71" (747 x 577 x 628 mm)	100	Single	1208	12.1	JIS C 8303	64 lbs (29 kg)
		120		1440	12.0	NEMA 5-15P	
		220-230 (CE)		1233-1347	5.6-5.9	CEE 7/7 Schuko	
		230-240 (CE)		1347-1468	5.9-6.1	BS-1363 or AS 3112•	

* Shipping weight includes packaging.

† AS3112 plug for use in Australia only.

‡ The GRFHS-PTT21 for Canada uses a NEMA 5-20P plug configuration.

CORD LOCATION

GRFHS-16, -21, -26, -PT26: Back side, lower right corner.

GRFHS-PTT21: Lower right-hand side.

PRODUCT SPECS

Glo-Ray® Fry Holding Station

The Glo-Ray Fry Holding Station shall be a Glo-Ray® Model ... as manufactured by the Hatco Corporation, Milwaukee, WI 53234 U.S.A.

The Fry Holding Station shall be rated at ... watts, ... volts, and be ... inches (millimeters) in overall width. It shall consist of either a stainless steel housing or an

aluminum housing with ceramic. Pre-set thermostatically controlled based heat. Portable warmer features wire guards, shatter-resistant incandescent display lights, a lighted on-off switch, and 6' (1829 mm) cord and plug. Comes with 24/7 parts and service assistance (U.S. and Canada only).

PLUG CONFIGURATIONS

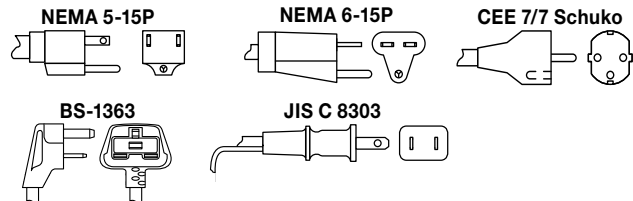

HATCO CORPORATION | P.O. Box 340500 Milwaukee, WI 53234-0500 U.S.A.

(800) 558-0607 | (414) 671-6350 | www.hatcocorp.com | equipsales@hatcocorp.com | intl@hatcocorp.com