



A VARIETY OF FOOD PRODUCTS SERVED HOT AND FLAVOR FRESH

The Hatco CDW-3N is designed to keep a variety of food products hot and flavor fresh until served. With a single non-humidified cavity, and a single temperature control, this unit provides dry, even heat for food products that do not require humidity. With insulated top, side, and back, these drawer warmers provide excellent energy efficiency.

CDW-3N



CDW-3N
Drawer Warmer

- Freestanding model has low profile 2" (51 mm) casters (two swivel with wheel locks and two swivel) as standard.
- Digital electronic controller for easy programming and temperature accuracy.
- Low velocity convected air system provides even temperature throughout the cabinet.
- Tough, solid chrome handles are angled to avoid glances from passing carts.
- Narrow width fits most kitchen footprints.
- Heavy-duty drawer slides with nylon rollers.
- Each drawer fits a standard 12.75"W x 20.75"D x 2.5", 4", or 6"H (324 x 527 x 64, 102, 152 mm) food pan or 12.75"W x 20.75"D x 6"H (324 x 527 x 152 mm) perforated food pan.
- 120 and 230 volts with 6' (1829 mm) cord and plug.
- Completely insulated single cavity provides maximum energy efficiency.
- Two-year warranty on heating elements, drawer rollers and slides.
- Includes three full size pans
- Accessory stainless steel food pans available

For quality when you need it, contact Hatco at
(800) 558-0607 or (414) 671-6350 or visit: www.hatcocorp.com





Convected Drawer Warmer

Model: CDW-3N

Convected Drawer Warmer

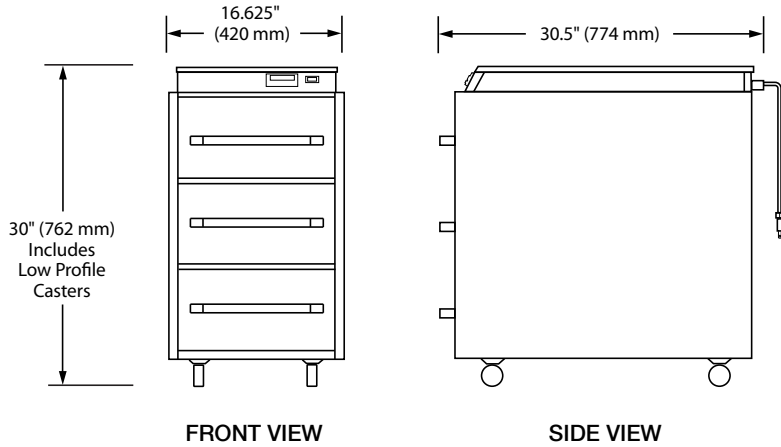

SPECIFICATIONS

Convected Drawer Warmer

The shaded areas contain electrical information for International models only.

Model	Dimensions (Width x Depth x Height†)	Volts	Phase	Watts	Amps	Plug	Ship Weight*
CDW-3N	16.625" x 30.5" x 30" (420 x 774 x 762 mm)	120	Single	1015	8.5	NEMA 5-15P	179 lbs. (81 kg)
		230		933	4.1	CEE 7/7 Schuko	
						AS 3112	
						BS-1363	

† Height includes low profile 2" (51 mm) casters (two swivel with wheel locks and two swivel).

*Shipping weight includes packaging.

CORD LOCATION

Back of unit, top right corner.

PLUG CONFIGURATIONS

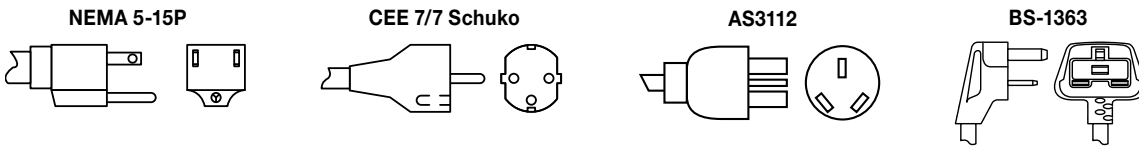

PRODUCT SPECS

Convected Drawer Warmer

The Drawer Warmers shall be a Hatco Model, freestanding unit manufactured by the Hatco Corporation, Milwaukee, WI 53234, U.S.A.

The unit shall havedrawer(s) and be rated atwatts,amps. Freestanding model shall be equipped with a cord and plug.

The Drawer Warmer shall have a stainless steel exterior, interior, drawer slides, and

assembly. Drawer rollers shall be durable nylon. The unit shall be insulated top and sides of cabinet with digital electronic controller and low velocity convected air system.

Accessories may include Stainless Steel Food Pans.

Warranty consists of 24/7 parts and service assistance (U.S. and Canada only).

HATCO CORPORATION | P.O. Box 340500 Milwaukee, WI 53234-0500 U.S.A. | (800) 558-0607 | (414) 671-6350

Fax: (800) 543-7521 | Int'l. Fax: (414) 671-3976 | www.hatcocorp.com | email: equipsales@hatcocorp.com